

Actuated Ball Valves (SBV60 Series)

Features

- Rack and pinion pneumatic actuator.
- Double acting and spring return mode.
- Operating Pressure : 3 ~ 8bar
- Rotating Angle : 90° ±3°
- Temperature Range : -20°C (-4°F) to 80°C (176°F).



Ordering Information and Dimensions

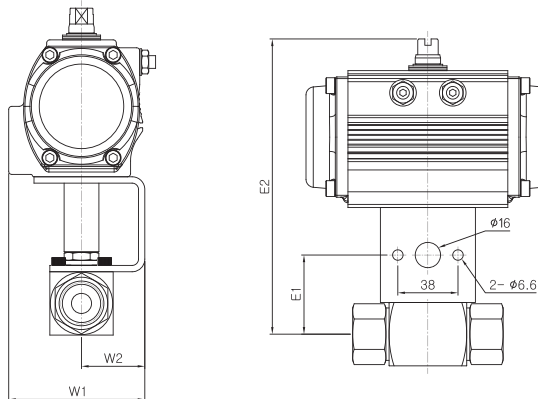

Valve Series	Dimensions (mm)			
	E1	E2	W1	W2
SBV1H	40.0	154.0	40.0	86.0
	40.0	154.0	40.0	86.0
SBV2H	50.0	186.5	40.0	86.0
	50.0	186.5	40.0	86.0
SBV3H	55.0	211.0	45.0	94.5
	55.0	211.0	45.0	94.5

SBV1H-S-4T

Valve Basic Ordering Number

PDA

Actuator Type Designator

- **PDA** : Double Acting
- **PNO** : Spring Return (Normal Open)
- **PNC** : Spring Return (Normal Close)

40

Actuator Series Designator

- **40** : R40 Actuator
- **50** : R50 Actuator(Standard for SBV1H)
- **65** : R65 Actuator(Standard for SBV2H)
- **80** : R80 Actuator(Standard for SBV3H)

S6

Valve Material Designator

- **S6** : 316 Stainless Steel

Torque Table for SBV60 Series

Valve Series	Torque (N-m)					
	1000psig	2000psig	3000psig	4000psig	5000psig	6000psig
SBV1H	1.0	1.8	2.5	3.3	4.0	4.8
SBV2H	2.0	3.7	5.4	7.0	8.7	10.4
SBV3H	4.7	9.0	13.3	17.6	21.9	26.3

↗ Actuator Dimensions

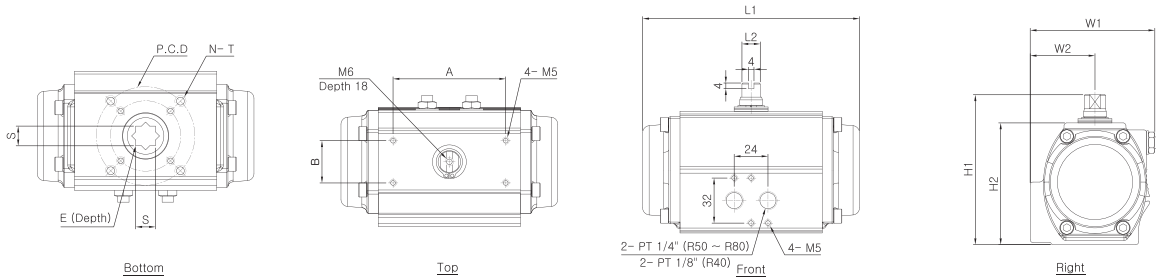

Actuator Series	ISO Flange Type	P.C.D	N- T	Dimensions (mm)										Weight (kg)	
				L1	L2	H1	H2	W1	W2	S	E	A	B	RD	RS
R40	F03/F05	36/50	4- M5/M6	97.0	9.0	75.0	55.0	63.0	32.0	9.0	9.0	50.0	25.0	0.5	0.6
	*F04	*42	*4- M5												
R50	F03/F05/F07	36/50/70	4- M5/M6/M8	133.0	9.0	90.0	70.0	75.0	40.0	11.0	13.0	80.0	30.0	1.0	1.1
	*F04	*42	*4- M5												
R65	F05/F07	50/70	4- M6/M8	154.0	13.0	106.5	86.5	89.0	46.0	14.0	16.0	80.0	30.0	1.4	1.5
	*F07	*70	*4- M8												
R80	F07	70	4- M8	220.0	19.0	126.0	106.0	101.0	49.5	17.0	19.0	80.0	30.0	2.9	3.3

* Option.

Torque Table for RD Series - Double Acting

Actuator Model	Supply Air (bar)														
	3		4		4.5		5		6		7		8		
	Torque (N·m)														
RD40-AL	5.5		7.4		8.4		9.2		11.1		13.0		14.8		
RD50-AL	9.4		12.5		14.3		15.9		19.1		22.5		25.8		
RD65-AL	18.3		24.7		27.8		30.8		36.8		42.9		49.2		
RD80-AL	44.5		58.9		66.5		74.4		89.3		104.3		117.8		

Torque Table for RS Series - Spring Return

Actuator Model	Supply Air (bar) to Open															
	3		4		4.5		5		6		7		8		Spring to Close	
	0°	90°	0°	90°	0°	90°	0°	90°	0°	90°	0°	90°	0°	90°	0°	90°
	Torque (N·m)															
RS40-AL	1.0	-	2.9	0.5	3.8	1.2	4.8	2.1	6.7	3.8	8.6	5.1	10.5	6.4	5.9	3.9
RS50-AL	4.1	1.2	7.4	4.4	9.0	6.1	10.7	7.6	14.2	11.1	17.3	14.5	20.8	18.0	8.1	5.2
RS65-AL	4.1	1.2	8.7	3.6	14.7	9.5	17.9	12.5	21.1	15.7	27.2	22.0	33.3	28.1	13.7	8.4
RS80-AL	21.1	6.1	35.3	21.0	42.9	29.1	50.5	35.7	65.6	51.3	80.8	66.4	95.7	80.5	33.7	21.7